

artemis pro



Diver Handheld Sonar & Navigator

ARTEMIS PRO is a handheld underwater computer that incorporates a target detection sonar, DVL, Camera, Dive-Light, Acoustic Positioning, Data Modem and GPS navigation aids, designed to assist commercial and search-and-rescue divers in locating objects on the seabed.

ARTEMIS PRO has also been specifically optimised for use by Naval Mine Clearance, EOD and Commercial Divers for locating and navigating to submerged targets as an alternative to conducting a tactile or circular search around a known datum, or large area survey work to identify objects on the seabed.

Artemis PRO includes...

- Multi-beam sonar, for high quality, fast frame rate sonar images in poor visibility conditions.
- Doppler Velocity Log (DVL) providing navigation information from the divers swim heading, velocity and height above the seabed.
- Integrated video camera and dive light.
- GPS antenna for getting absolute diver position fixes when surfaced.
- AHRS sensors to provide magnetic heading information and monitor orientation.
- Optional Camera, Dive-Light and USBL-based Acoustic Positioning transponder (& Data Modem).
- Immersion sensor that automatically starts data logging when the diver submerges.
- Pressure and water temperature sensors.
- Quick-change battery pack.

Typical uses are:

- Search and relocation of unexploded ordnance by naval mine clearance divers, commercial EOD divers, etc.
- location of photographic/video survey of seabed infrastructure within the offshore oil & gas environment (e.g. pipelines, well heads, structures).
- Location and identification of lost property, vehicles, aircraft, missing persons, wrecks by police or search & rescue divers.
- Sub-surface navigation, area survey and bottom profiling operations.

Features

artemis pro



ARTEMIS PRO is intuitive and straightforward to use. The interface has been designed by divers for divers. The user can quickly interpret information presented via the simple menu interface and graphical display, and easily switch between Sonar, Navigation and other displays with the touch of a button.

ARTEMIS PRO is almost neutrally buoyant. The lanyard supplied can be attached to a D-Ring or other securing point on the diver, enabling the unit to hang free during descent/ascent when the diver may need to operate gas valves or other life-support apparatus.

ARTEMIS PRO is a self-contained system. The console is fitted with a 7" colour display and simple 10-button keypad. The battery pod is mounted below the unit allowing rechargeable battery-packs to be swapped quickly between dives.

Sonar Imaging

For its target search and identification role, the forward imaging sonar uses multi-beam technology to provide near-instantaneous updates of the whole field-of-view at rates up to 20 times per second. Dual frequency operation allows a good balance between long range initial detection coupled with excellent short range detail.

The information provided by the **130° field of view** from the sonar is especially useful in poor visibility/darkness as the diver makes his final approach to an unknown or unidentified target.

For relocation of large objects such as wrecks, jetties, underwater swimmer delivery vehicles etc., it is possible to use the maximum **range of 120m**. Once the object has been detected, the diver can close the range, changing the sonar frequency and display scale as the target approaches.

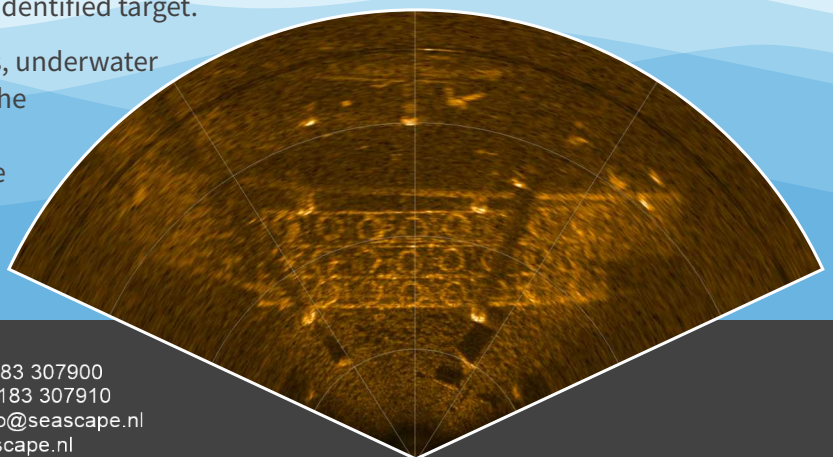

Navigation & Bottom Tracking

For diver navigation and positioning ARTEMIS PRO combines several sensors: an internal GPS antenna is used to get an absolute position fix when the diver is at the surface, then once the diver submerges the **Doppler Velocity Log (DVL)** and **AHRS sensors** provide a "dead reckoning" based navigation solution.

The output from the DVL also tracks the height of the diver above the seabed and this information, in conjunction with the pressure sensor data, gives **total water column depth**. Position drift over time can be corrected by augmentation with occasional GPS locations or acoustic fixes from the USBL positioning system.

Additionally, the acoustic positioning system includes a bidirectional data links allowing the surface supervisor to track the divers progress, and communicate with the diver via text message.

Mission files can be created containing **waypoint and target markers** that can assist the diver in navigating a search-pattern or efficiently swim between locations.

The diver's **position, velocity, heading, depth** and **course history** are shown on ARTEMIS PRO's display with any selected mission marker. Additional points of interest may also be added during the dive and reviewed post-dive.

Swim Guide

Regardless of the main display being shown, the status bar is always visible along the bottom of the screen.

In addition to a selection of coloured status icons (showing Power, Sonar, DVL, GPS, Logging and Immersion states), the status bar also provides the diver with "**heading to swim**" directions for the currently selected navigation destination.

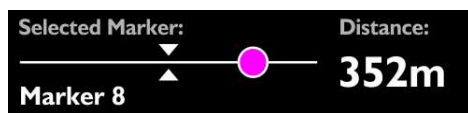

If the diver is more than 30°, 60° or 90° off the desired heading, 1, 2 or 3 arrows indicate respectively that they should turn either left or right. Below 30°, a circular 'bubble' moves across the status bar to allow fine tuning of the course.



Mission Planning & Dive-Log Review

"PinPoint" is a PC Windows software application (supplied with ARTEMIS PRO). It can be used pre-dive to create **Mission Files** that configure ARTEMIS PRO with navigation marker locations (waypoints, targets of interest, etc). Post-dive, it can review the data collected in **Dive-Log Files** and display information such as the route taken by the diver, additional targets marked during the dive, the divers depth profile and seabed profile.

Mission markers can be entered in text form, positioned over imported **S57/S63 nautical charts** or from other third-party sources (such as Google Earth) in formats including CSV, GPX or KML.

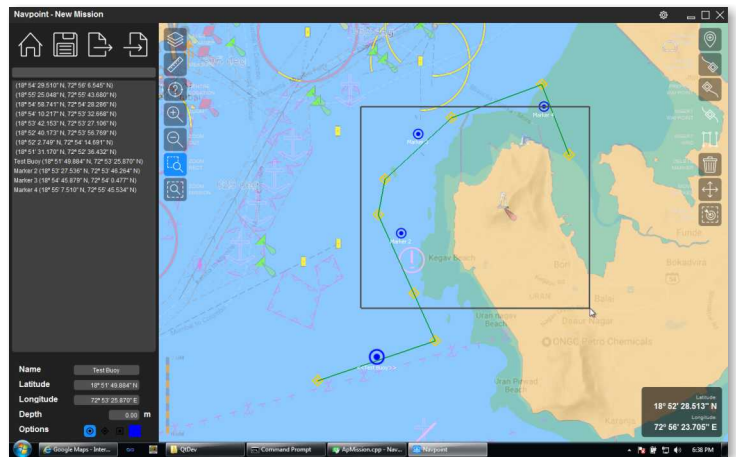

During a dive, ARTEMIS PRO will collect and record all the sensor information received from the Sonar, GPS, DVL, internal compass and depth sensor into a Dive Log file.

Once the dive is complete, Dive-Log files can be copied onto the PC and reviewed using "PinPoint".

Intuitive displays show the **synchronised playback** of all sensor data on a variety of intuitive and interactive displays.

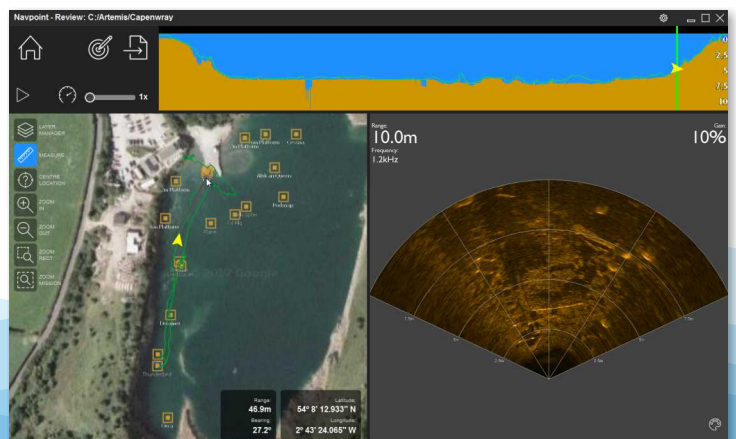

Divers have a lot on their mind, so ARTEMIS PRO's user interface has been designed to be simple and intuitive to use...

Keypad

ARTEMIS PRO only requires 10 buttons on its keypad, and using a **solid-state "piezo" pressure sensing technology** they require only a gentle push to activate either at the surface or at depth. Machined into the aluminium housing there are no moving parts or additional seals, greatly reducing the risk of the housing flooding.

Displays

To help the diver perform complex tasks while keeping the user interface simple and uncluttered, ARTEMIS PRO has several distinct displays for each type of diver task.

Pressing the HOME button allows the diver to quick change between displays depending on weather they are searching for object on the sea bed, navigating a course or surveying an area.

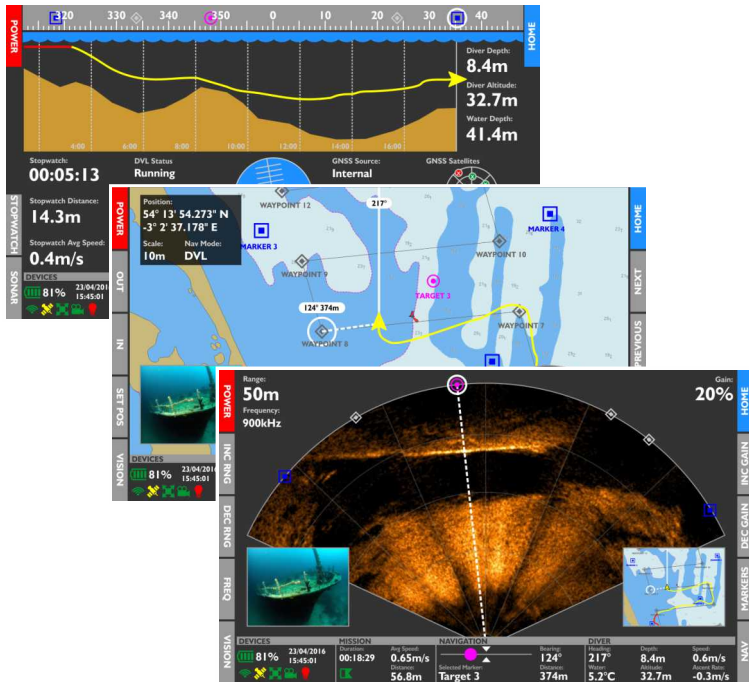

Ordering Options

ARTEMIS PRO is fitted with an Oculus M750d multibeam imaging sonar as standard but can be supplied with other frequency options such as the M1200d 1.2MHz/2.1MHz sonar.

Video Camera, Dive-light and USBL Acoustic Positioning & Comms are options that should be specified at the time of ordering.

DA-150-D00261-05

Specifications

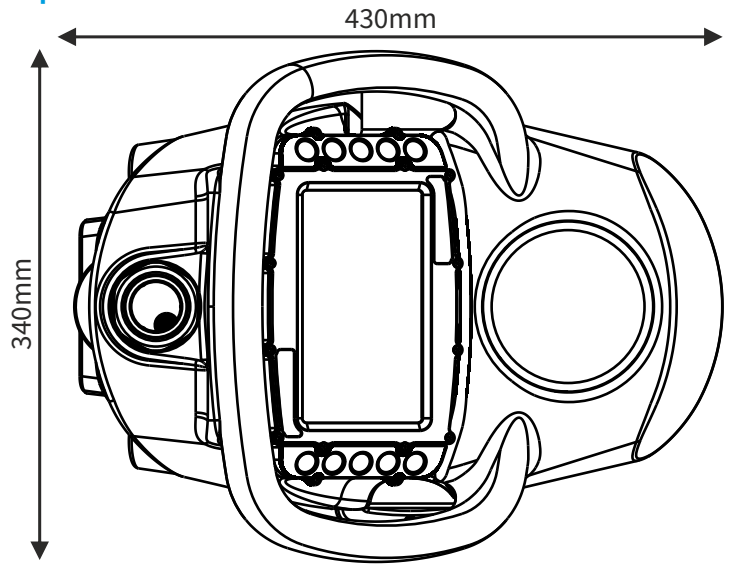

Mechanical

Dimensions	430mm long × 340mm wide × 200 mm high
Weight	~11kg in air, ~0.25kg max in water (sensor dependant)
Operating Temp.	-10°C to +45°C
Operating Depth	80m sea water

Electrical

Screen	Tilted 7", 1024 × 600 pixel, 16-bit colour Liquid Crystal Display with adjustable back-light brightness.
Data Logging	Data logging to internal Solid state drive - 512Gb & 1Tb options available.
Integrated Sensors	Pressure, Water Temp, Attitude/Heading (pitch & roll, compass, rotational rate gyros), Battery voltage
User Interface	10 × solid-state piezo button interface for menu navigation and parameter control
Communications	USB2.0 480Mbps port for connection to a PC.

Battery Pack

Operating Time	6-8 hours typical use from charged battery pack.
Charing Time	Approx 4 hours from fully discharged state.
Charger Supply	90-264V AC Mains at 50-60Hz

Sonar

Frequency	750kHz / 1.2MHz dual-frequency multi-beam
Beam Geometry	20° vertical, 130°/70° horizontal
Range Settings	1m up to 120m/40m (sonar frequency dependant)

GNSS Navigation

GNSS Receiver	72-channel GPS L1 C/A, GLONASS L10F, BeiDou B1I, Galileo E1B/C. 2.0m CEP Position Accuracy.
----------------------	---

Doppler Velocity Log (DVL)

Beam Geometry	4 beams, 2.4° conical, Janus configuration
Frequency	1MHz
Range	>50m bottom tracking
Velocity Resolution	1mm/second

Please note that all specifications may be subject to change in line with our policy of continual product development.